

MET7A laser methanometer



Technology description

Optimization of the combustion process and meeting safety conditions requires the continuous, accurate and immediate measurement of the methane concentration in the supply line.

This results from the variable parameters of the gas which are related to the technology of obtaining methane from coal seams, such as the concentration of methane and other mine gases, water vapour content, etc.,.

The operating principle of MET7A methanometer, whose original design was constructed by GIG, is based on the selective absorption of laser radiation in the mid-infrared range.

The metrological parameters achieved (linearity of the characteristics, reaction time, accuracy and selectivity of the measurement) and the structure adjusted to specific industrial conditions enabled the use of these devices in systems used for controlling methane burners. The appropriateness of the applied solutions has been verified during three years of operation in heating plants burning gas which originated from methane drainage in various hard coal mines.

DEPARTMENT OF TECHNICAL ACOUSTICS
AND LASER TECHNOLOGY
Laboratory of Technical Acoustics

Ph. Sc., Prof. GIG Janusz Kompala
E: jkompala@gig.eu
T: +48 32 259 22 34

MET7A laser methanometer

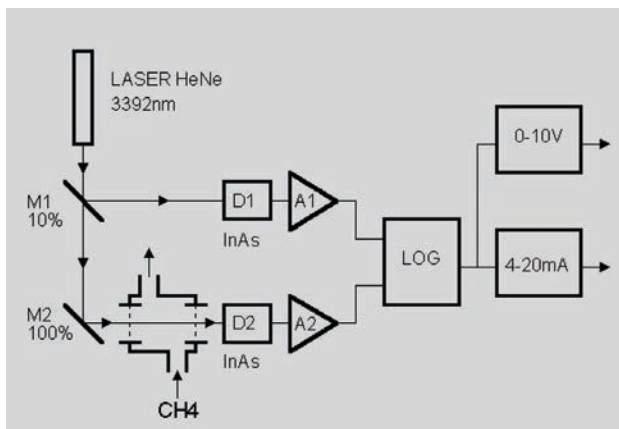

The advantages of this technology

The tests carried out in certified units showed the assumed accuracy of the methane concentration measurement, the linear characteristics of the device, and resistance to the presence of other mine gases, water vapour and dust.

Application

Controlling the work of methane burners in boilers adapted (for economic and ecological reasons) to the combustion of methane obtained from hard coal mines.

Technical data:

- measuring range: 0-100% vol.
- accuracy + 1%
- power supply: $\sim +230 + 10 - 15\%$
- power: 30VA
- output signal (measuring): 4-20 mA, 0-10 V
- control output: relay OPEN - ERROR, CLOSE - O.K.
- measuring head: weight 10 kg, dimensions 120x120x200
- signal processing module: weight 5 kg, dimensions 400x400x210

